

Measuring the CO₂ flux at the air/water interface in lakes using flow injection analysis

F. V. Almeida,^a J. R. Guimarães^b and W. F. Jardim^a

^aInstituto de Química, UNICAMP, Cx. Postal 6154, 13083-970 Campinas, São Paulo, Brazil.
E-mail: falmeida@iqm.unicamp.br; E-mail: wffjardim@iqm.unicamp.br

^bFaculdade de Engenharia Civil, UNICAMP, Cx. Postal 6021, 13083-970 Campinas, São Paulo, Brazil. E-mail: jorober@fec.unicamp.br

Received 18th December 2000, Accepted 3rd April 2001

First published as an Advance Article on the web 11th May 2001

The carbon dioxide flux at the air/water interface in lakes was calculated after the determination of H₂CO₃* (free CO₂) and atmospheric CO₂ using flow injection analysis (FIA) coupled to a conductometric detector. The method is based on the diffusion of CO₂ through a hydrophobic membrane into a flow of deionized water, generating a gradient of conductivity proportional to the concentration of CO₂ in the sample. Using one experimental set-up, the speciation of the inorganic carbon (H₂CO₃* and dissolved inorganic carbon) was accomplished by simply adjusting the sample pH. The determination of CO₂ in the atmosphere was carried out by direct injection of the gaseous samples. The FIA apparatus was taken into the field and CO₂ fluxes were evaluated in several Brazilian lakes. In these lakes, representing different eutrophic stages, the CO₂ flux varied from -242 (invasive) up to 3227 (evasive) μmol CO₂ m⁻² h⁻¹.

1. Introduction

The exchange of CO₂ across the air/water interface is an important parameter for understanding the processes related to the carbon cycle within the aquatic environment. The direction of CO₂ gas exchange depends on the concentration gradient between the air and water surface, whereas the magnitude of the exchange depends additionally on the gas exchange coefficient.¹ Carbon dioxide gain and loss occur simultaneously in lakes from inputs of CO₂-rich underground water, variations in primary production and dissolution or precipitation of carbonate compounds within the system. In contrast to the oceans, which act mainly as net sinks for CO₂, freshwater systems can behave either as sinks or as sources of atmospheric CO₂. Data from 1835 lakes worldwide showed that 87% were CO₂ supersaturated with respect to the atmosphere.²

In the water column, CO₂ reacts with H₂O and, depending on the pH, directly with OH⁻, producing H₂CO₃*, HCO₃⁻ and CO₃²⁻. In a closed system, the concentration of dissolved inorganic carbon (DIC) is obtained using the expression:

$$\text{DIC} = [\text{H}_2\text{CO}_3^*_{\text{aq}}] + [\text{HCO}_3^-_{\text{aq}}] + [\text{CO}_3^{2-}_{\text{aq}}] \quad (1)$$

where

$$[\text{H}_2\text{CO}_3^*_{\text{aq}}] = [\text{H}_2\text{CO}_3_{\text{aq}}] + [\text{CO}_2_{\text{aq}}] \quad (2)$$

Using the thermodynamic constants for carbonic acid, K_1 and K_2 , eqn. (1) can be solved for H₂CO₃* as a function of pH:

$$[\text{H}_2\text{CO}_3^*_{\text{aq}}] = \text{DIC} \{ [\text{H}^+]^2 / (K_1 K_2 + K_1 [\text{H}^+] + [\text{H}^+]^2) \} \quad (3)$$

For aqueous samples showing pH values below 8, the concentration of CO₃²⁻ species is very small compared to the concentrations of the other two aqueous species (H₂CO₃* and HCO₃⁻) present in solution, and can be neglected in a first approximation. Therefore, eqn. (3) can be rewritten as:

$$[\text{H}_2\text{CO}_3^*_{\text{aq}}] = \text{DIC} / \{ (K_1 / [\text{H}^+] + 1) \} \quad (4)$$

allowing the calculation of H₂CO₃* as a function of pH.

Carbon dioxide species in aqueous solutions open to the atmosphere, and at equilibrium, are usually calculated using two out of four parameters: DIC, total alkalinity (TA), pH and the atmospheric partial pressure of CO₂ ($p\text{CO}_2$), together with the thermodynamic constants.³⁻⁶ The choice is made according to the aim of the work and the facility of the measurements.⁷ However, it is important to bear in mind that equilibrium conditions are rarely attained in natural water bodies and, in this situation, calculated H₂CO₃* values may differ markedly from the values obtained in realistic conditions, such as in field measurements.

The use of flow analysis for the determination of dissolved carbon dioxide by membrane separation was first reported by Carlson.⁸ The method was based on the transfer of carbon dioxide by diffusion through silicone-rubber hollow fibres into a flowing stream of deionized water, followed by electrical conductivity detection. Pasquini and de Faria⁹ proposed a flow injection analysis (FIA) system for the measurement of ammonia based on gas diffusion through a PTFE membrane and measurement in a conductance flow cell. Later, Jardim *et al.*,¹⁰ based on this ammonia system, used the diffusion process to monitor aqueous CO₂ production from *Escherichia coli* in toxicity tests. More recently, other authors have also published articles based on the same system for the determination of DIC.^{11,12}

According to a recent review by Pasquini and Silva,¹³ despite the numerous papers dealing with FIA, only a few deal with the direct injection of gaseous samples. In this work, a flow injection system with a conductometric detector was developed for the determination of DIC and H₂CO₃* in aqueous samples, as well as the concentration of CO₂ in the atmosphere ($p\text{CO}_2$). This method introduces the novel approach of injecting gaseous samples (atmosphere) directly into the carrier.

Initially, the whole experimental set-up was evaluated according to its ability to measure H₂CO₃*, and consequently DIC, in a closed reactor, at known conditions (pH and ionic strength). Later, using the optimized set-up in the field, the determination of H₂CO₃* and $p\text{CO}_2$ was carried out *in situ* and without disturbing the natural condition of the sample. The major advantage of the proposed method is that the speciation

of inorganic carbon in aqueous samples is carried out experimentally and not inferred with the use of thermodynamic parameters. In addition to this, the same system set-up also allows the injection of gaseous samples to accomplish the determination of atmospheric CO₂.

2. Experimental

2.1. Reagents

Water used in the conductivity experiments was obtained from a Milli-Q reagent-grade water system (Millipore Corp.). The H₂SO₄ solution and the stock solution of NaHCO₃ were prepared from analytical grade reagents (Merck, Germany). The working reference NaHCO₃ solutions were prepared by dilution of the stock solution just before use.

2.2. Apparatus and experimental set-up

The system manifold is shown in Fig. 1. The experimental procedure is based on the previous work of Pasquini and de Faria⁹ and Jardim *et al.*,¹⁰ where specific details about laboratory-made components are provided. Basically, the method is based on the diffusion of CO₂ through a non-wetting, gas porous membrane (PTFE) that is supported by an acrylic cell (diffusion cell). The permeating gas is collected in a stream of freshly distilled and deionized water (the acceptor stream) that flows towards a microconductivity cell (40 μL volume). The conductivity meter (Micronal B372) output is plugged to a strip-chart recorder (Cole-Parmer 8376-20). A peristaltic pump (Ismatec MS-Reglo, four channels, and variable speed) is used to circulate the fluids at a flow rate of 2.5 mL min⁻¹. The injection valve (V) is used to insert both gaseous and aqueous samples into the system. The system allows the injection of non-perturbed samples, yielding values of H₂CO₃^{*}, acidified samples, yielding values of DIC, and gaseous samples in the determination of atmospheric CO₂.

2.3. Calibration of the FIA for H₂CO₃^{*} measurements

For performing direct measurements of dissolved CO₂, the experimental set-up was first coupled to a headspace-free reactor containing sodium bicarbonate solution. In this set-up, the injection valve, shown in Fig. 1, was removed and the glass piston reactor was connected directly to the donor stream. Fig. 2 shows the 700 mL volume reactor made of borosilicate glass and containing three different apertures. The first aperture was used to insert the glass-combined electrode (Orion, 8104 Ross) for continuous pH measurements. The second aperture was used to withdraw the solution to the FIA system, and the third was used to add known volumes of 0.5 mol L⁻¹ H₂SO₄ in order to alter the solution pH towards more acidic values. The reactor with a glass piston acted as a

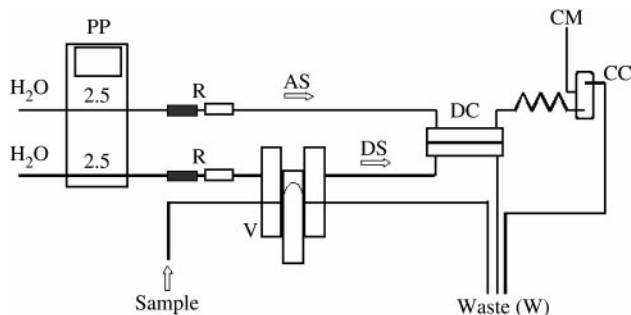

Fig. 1 Flow manifold used in the inorganic carbon speciation (reagent injection mode) and atmospheric CO₂ measurement: peristaltic pump (PP); sample or standard introduction valve (V); mixed-bed resins (R); diffusion cell (DC); conductance cell (CC); conductivity meter (CM); waste (W); acceptor stream (AS); and donor stream (DS).

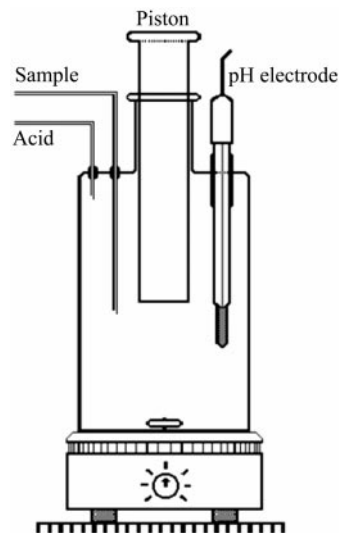

Fig. 2 Headspace-free reactor used in the determination of H₂CO₃^{*} using standard bicarbonate solutions.

reservoir and allowed the sampling of up to 50 mL of solution without the formation of headspace.

The calibration involved changing the pH of the NaHCO₃ solution and reading the CO₂ values until no further changes in the conductivity were noticed. After reaching the steady state, new addition of acid was made and the system was allowed to equilibrate, generating a new value for the CO₂ concentration. The final shape of the register is a staircase form (Fig. 3a).

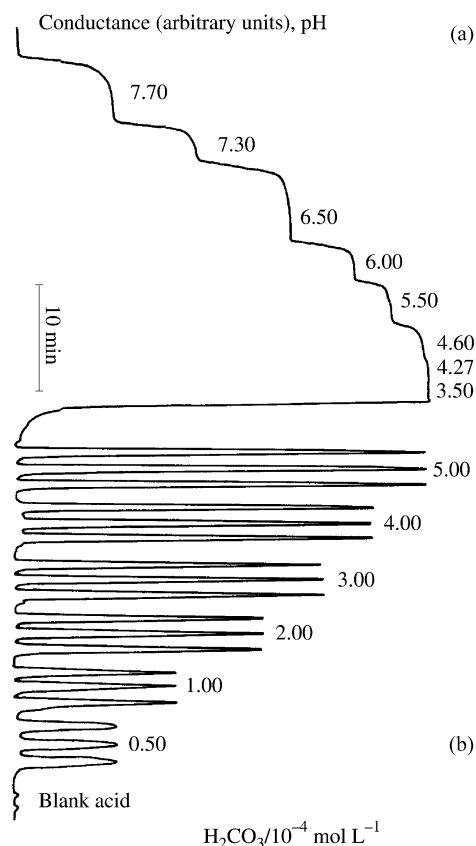

Fig. 3 (a) Calibration curve in the staircase form. Results obtained using the headspace-free reactor. The numbers above each step indicate the measured pH. (b) Calibration curve obtained through injection of standards for three replicates of different bicarbonate standard solutions.

During the pumping of the bicarbonate solution to the diffusion cell, a headspace-free system was ensured by the presence of the piston. When the pH inside the reactor reached values below 4, the concentration of H_2CO_3^* equalled the value attained for DIC. Considering this closed system, experimental values obtained for H_2CO_3^* could be compared with theoretical ones obtained using pH, K_1 and the ionic strength.

2.4. Sampling locations and methodology

Sampling was carried out in four Brazilian lakes: Lake Tupé (60°15' W, 03°03' S) and Calado (60°34' W, 03°15' S), both marginal lakes of the Amazonas River; Óleo Lake (47°50' W, 21°35' S), a marginal lake of the Mogi-Guaçu River, São Paulo State; and Taquaral Lake (47°03' W, 22°52' S), an artificial and hypereutrophic lake in the city of Campinas, São Paulo State.¹⁴ The FIA system was transported to the field, close to the sampling points, in order to allow *in situ* analysis.

Óleo Lake, a waterflood basin, was sampled four times on each survey day in order to evaluate diurnal variation in both $p\text{CO}_2$ and H_2CO_3^* . The first sampling was performed in October 1997 (cold and dry season), and the second in March 1998 (hot and rainy season). Water samples from Óleo Lake were also collected at different depths, with a Kemmerer bottle. Amazonian lakes were sampled during the wet season (in May 1997) when the lake depths reached 10 m. Taquaral Lake was sampled three times in October 1997, during one day.

Surface water samples were collected in a 60 mL plastic (polyethylene) syringe, taking special care to keep a headspace-free condition; the atmosphere was also sampled with 60 mL plastic syringes, through 30 m polyethylene tubing (id, 1.5 mm) fixed in a floating device, in order to avoid interference caused by the CO_2 exhaled by the sampler. Almeida¹⁵ established that gaseous and aqueous samples collected and stored in polyethylene syringes and equipped with a three-way valve suffered no change in H_2CO_3^* and $p\text{CO}_2$ for a period shorter than 3 h. Air samples were injected directly into the unit's injection valve from the syringes, where the sample loop in the injection valve was responsible for ensuring the same volume of sample to be used in the CO_2 determination.

3. Results and discussion

3.1. Checking the FIA performance for measuring aqueous CO_2

The preliminary steps of the experimental procedure involved the validation of the system to perform inorganic carbon speciation. The headspace-free reactor was fully filled with a solution containing $5.00 \times 10^{-4} \text{ mol L}^{-1} \text{ NaHCO}_3$ and $0.05 \text{ mol L}^{-1} \text{ NaNO}_3$ to adjust the ionic strength. Keeping the temperature constant at 22 °C, the solution was submitted to a rapid mixing, after the addition of 15 μL of $0.1 \text{ mol L}^{-1} \text{ H}_2\text{SO}_4$, using a 2000 μL microburette. On acidification, the amount of CO_2 crossing the PTFE membrane increases as a consequence of the carbonate equilibrium. This causes an increase in the conductivity of the deionized water stream receiving the diffused CO_2 . As a consequence, the monitored signal increases and reaches a plateau. This situation is only changed on new addition of acid, as already discussed in Section 2.3.

The concentration of H_2CO_3^* in Fig. 3a was experimentally determined using this experimental set-up and compared with the theoretical values expected for the experimental conditions used (pH, NaHCO_3 concentration and the equilibrium constants at the selected temperature and ionic strength). When theoretical and experimental H_2CO_3^* values are plotted against pH (Fig. 4), both curves show excellent agreement, thus validating the proposed method.

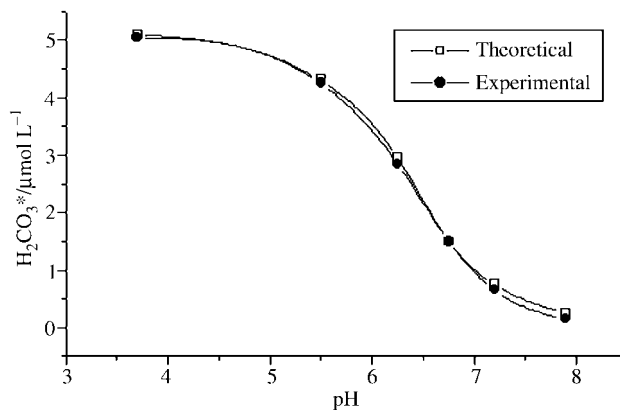

Fig. 4 Theoretical and experimental H_2CO_3^* against pH using the headspace-free reactor. Conditions: $T=22^\circ\text{C}$; $pK_1=6.38$; $I=0.05 \text{ mol L}^{-1}$; $\text{NaHCO}_3=5 \times 10^{-4} \text{ mol L}^{-1}$.

3.2. Optimizing the system for field measurements of CO_2

The system had to be optimized in order to measure both aqueous and gaseous samples using the same experimental set-up. The main difference between measuring aqueous and gaseous CO_2 is the amount of gas permeating the diffusion cell. For $p\text{CO}_2$ determination, the amount of CO_2 crossing the membrane is very low compared to that for aqueous samples. For this reason, a 60 cm long PTFE reaction coil (id, 0.8 mm) was placed between the permeation and conductivity cell (CC) to increase the hydration time of the CO_2 and thus to improve the sensitivity. Two columns of ion exchange resins (cationic and anionic) were also introduced in both donor and acceptor streams (see Fig. 1) to decrease the baseline conductivity signal and, consequently, increase the sensitivity. The flow rate was maintained at 2.5 mL min^{-1} for both donor and acceptor streams because it generated better analytical throughput and sensitivity for both gaseous and aqueous samples.

3.3. Measuring gaseous CO_2

Measurements of gaseous CO_2 were performed with the help of a calibration curve constructed using a simple gas dilution procedure. Initially, a 2.0 L Erlenmeyer flask was calibrated by using the classical analytical procedure of glassware calibration through the water density. The flask was flushed with nitrogen and sealed with a rubber septum. Before any CO_2 addition, around 2 mL of this CO_2 -free atmosphere was collected from the Erlenmeyer flask, using a 3 mL plastic (polyethylene) syringe, and injected directly from the syringe into V (injection valve from the FIA system, Fig. 1), creating a gaseous segment in the carrier stream and generating the blank signal. Each injection was repeated three times.

The calibration curve was generated by adding previous selected volumes of gaseous CO_2 , using a 500 μL gas-tight syringe, to the calibrated Erlenmeyer flask containing nitrogen, followed by injection in the FIA system (as described above). The gaseous CO_2 was obtained by simply placing around 10 g of solid (99.9% pure) CO_2 in a small flask (250 mL), partially covered with polyethylene film, which saturated its atmosphere due to sublimation of the solid.

The sampling volume injected was 300 μL (easily adjusted according to the sample loop size in the valve V) in order to improve sample throughput and avoid peak distortion due to insufficient mixing in the acceptor stream. Under these conditions, the analytical frequency in the field was 48 h^{-1} . The detection limit, calculated according to Miller and Miller,¹⁶ was $10 \mu\text{mol L}^{-1}$ with a relative standard deviation of 1.8% when working with 300 μL of sample ($n=15$), which can be considered to be very suitable for the measurement of CO_2 flux at the water/air interface.

3.4. Measuring DIC and H₂CO₃*

An analytical calibration curve was constructed by adding a few millilitres of H₂SO₄ to a series of NaHCO₃ analytical solutions (50–500 μmol CO₂ L⁻¹) until pH 3.5 just before injecting the sample. In this procedure, the conductivity signal appears in the shape of a peak and not as that previously described (Fig. 3b). A quadratic (rather than a linear) equation describes the signal response as a function of carbon concentration due to the behaviour of H₂CO₃ as a weak electrolyte.

The injection volume used in the determination of H₂CO₃* was optimized to 1000 μL, the minimum volume necessary to reach steady state conditions for the non-perturbed samples. Results obtained using this procedure refer to the concentration of H₂CO₃*. In the determination of DIC, 50 mL of sample was filtered using 0.45 μm membrane (Millipore), and a few millilitres of H₂SO₄ were added immediately prior to sample injection. The injection volume was 150 μL.

Based on the optimized conditions, the flow system showed a sampling frequency of 45 h⁻¹ for DIC and 30 h⁻¹ for H₂CO₃*. The detection limit was 3 μmol L⁻¹ with a relative standard deviation of 1.2% when working with a sample volume of 1000 μL (*n* = 20) for H₂CO₃*. For DIC, the detection limit was also 3 μmol CO₂ L⁻¹ with a relative standard deviation of 1.9% when working with a sample volume of 150 μL (*n* = 6).¹⁶

Positive interference in DIC measurements may be caused by volatile organic and inorganic acids and oxides able to permeate the PTFE membrane and dissociate (mainly formic and acetic acid, H₂S, NO₂ and SO₂). For H₂CO₃*, due to the fact that the pH is not adjusted to values below 4 prior to the measurements, ammonia and volatile organic bases may cause interference. These compounds, however, are usually present in such low concentrations that they pose no bias when compared to the inorganic carbon species present in natural waters.

3.5. Empirical flux equations

Gaseous carbon dioxide is very soluble in water. It follows Henry's law under low partial pressure and concentrations:

$$[p\text{CO}_2] = K_{\text{H}}[\text{H}_2\text{CO}_3^*]_{\text{eq}} \quad (5)$$

where *K_H* is Henry's constant and *p*CO₂ is the partial pressure of CO₂ at equilibrium with H₂CO₃* in the water body. Using the global average *p*CO₂ value (356 ppmv) and considering *K_H* = 3.39 × 10⁻²,¹⁷ one should expect H₂CO₃* to be 1.21 × 10⁻⁵ mol L⁻¹.

The transfer of CO₂ between the gas phase (*i.e.* air) and water, when the two phases are in contact, will depend mainly on the gradient of CO₂ at this interface. The water/air interface can be considered as a stagnant boundary layer, and the transport from the water to the air, or *vice versa*, is governed by Fick's law [eqn. (6)]:

$$F = K[C^{\text{atm}} - C^{\text{aq}}] \quad (6)$$

where *K* is the gas transfer velocity and the term in square brackets is the difference in CO₂ concentration between the two phases.

For CO₂, a reactive gas, the gradient across the air/water interface will not always be constant, especially for natural waters with high pH values, since the reaction of dissolved CO₂ with OH⁻ ions is expected. For this reason, the theoretical calculation involving the transport of CO₂, which takes into account the diffusion and reactive processes, is a time-consuming and complex task. When working with natural systems, instead, the use of empirical flux equations is a suitable option to overcome this problem. In this case, the parameters to be determined are the concentrations of CO₂ in water and in

air, the temperature of the upper water layer and the wind velocity at the water surface.

For unenhanced exchange, many empirical equations for transfer velocity have been proposed in the literature. In this work, the equation proposed by Wanninkhof *et al.*¹⁸ is used, which is dependent on the wind speed according to:

$$K_{\text{CO}_2} = 0.76\mu[600^{0.67}/(Sc_{\text{CO}_2})^{0.67}], \text{ for } \mu < 3 \text{ m s}^{-1} \quad (7)$$

$$K_{\text{CO}_2} = ((5.6\mu) - 14.4)[600^{0.5}/(Sc_{\text{CO}_2})^{0.5}], \text{ for } \mu > 3 \text{ m s}^{-1} \quad (8)$$

where *Sc* is the Schmidt number for CO₂ at 20 °C and *μ* is the wind velocity measured at the water surface.

3.6. Flux calculations

The major problem concerning the use of eqn. (4) for the speciation of aqueous CO₂ is that *K₁* values are not always available, especially when the ionic strength is not known with accuracy. Furthermore, for freshwater samples, the low ionic strength and sample exposure to the atmosphere may cause errors in pH readings mainly due to the slow response of the electrode, markedly affecting the values of the theoretically calculated H₂CO₃*.¹⁹

In spite of all the corrections that can be made to minimize the errors associated with the equilibrium constants and the pH measurements, many authors still observe deviations in H₂CO₃* when compared to the values obtained from alkalinity measurements. For example, Butler and Mackey⁴ carried out an evaluation of *p*CO₂ via pH and alkalinity in the Tasman Sea and around New Zealand. The data obtained using the pH values and the alkalinity calculated from the surface salinity were approximately 20 μmol L⁻¹ lower than those obtained using an infrared gas analyser. On the other hand, Frankignoulle *et al.*²⁰ carried out a study in a polluted estuary (the Scheldt), using pH and total alkalinity measurements to calculate H₂CO₃* (expressed as *p*CO₂^{aq}) in the water column, and observed lower errors. They ranged from 6 μatm, in seawater, to 65 μatm (2.9 μmol L⁻¹, expressed as H₂CO₃*) in freshwater.

According to the results obtained in the present work, Óleo Lake is supersaturated with H₂CO₃* compared to the overlying atmosphere (Fig. 5). From the measurements carried out in two surveys, the mean value for CO₂ in surface water was 7977 ± 4045 μatm. The values of H₂CO₃* have been converted to μatm following the tendency observed in the literature.^{1,20} The diurnal variation in H₂CO₃* in the two surveys was small in comparison to the CO₂ supersaturation. In both cases, measurements over a 24 h period failed to indicate any significant diurnal variation in CO₂. On the other hand, it is apparent that supersaturation is a depth-related phenomenon

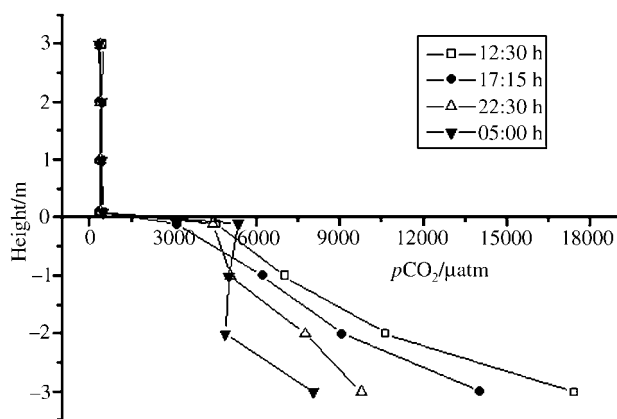

Fig. 5 *p*CO₂ in the water and air from Óleo Lake measured in October (cold and dry season). The height at 0 m represents the water surface.

Table 1 Some physicochemical characteristics and measured CO₂ flux as a function of time across the water/air interface of Lake Taquaral

Characteristic	Time			Average value
	6:30 h	10:45 h	15:30 h	
pCO ₂ ^{aq} /μatm	45 ± 1	13 ± 1	10 ± 1	23 ± 19
pCO ₂ ^{atm} /μatm	422 ± 1	392 ± 3	450 ± 2	421 ± 29
pH	9.1	9.5	9.6	9.4 ± 0.3
DO/mg O ₂ L ⁻¹	9.9	11.8	12.5	11.4 ± 1.4
Flux/μmol CO ₂ m ⁻² h ⁻¹	-105	-116	-142	-121 ± 19

Table 2 CO₂ partial pressure and estimated flux across the water/air interface for some Brazilian lakes

Lake	pCO ₂ ^{atm} /μatm	pCO ₂ ^{aq} /μatm	Flux/μmol CO ₂ m ⁻² h ⁻¹
Tupé	421 ± 5	3187 ± 29	3227
Calado	464 ± 8	1121 ± 22	1852
Óleo (October, 1997)	389 ± 50	4355 ± 900	1081
Óleo (March, 1998)	427 ± 26	11599 ± 1543	3383

and the probable causes of this supersaturation at depth are the production of CO₂ by sediment microbial respiration and the influx of CO₂-rich underground water.²¹

The two Amazonian lakes sampled are representative of so-called black waters: low pH values (average pH 4.7) and high dissolved organic carbon (DOC), with average values around 15 mg C L⁻¹. In these waters, humic materials act as protolytes, thus altering the values of DIC obtained *via* alkalimetric titration. The H₂CO₃* values obtained were much higher than the value expected for atmospheric equilibrium. Consequently, these lakes are acting as a source of CO₂ to the atmosphere.

Taquaral Lake was the only sampled reservoir that showed undersaturated CO₂ values, relative to the overlying air. Based on H₂CO₃*, dissolved oxygen data (9.9–12.5 mg O₂ L⁻¹) and gaseous CO₂ in the overlying air, at three different periods in a day (Table 1), this hypereutrophic reservoir may be acting as a sink for gaseous CO₂. In addition, the increase in the evasive flux is a function of solar radiation intensity, *e.g.* primary production.

The data from fieldwork showed that, in all the oligotrophic lakes studied, the concentration of dissolved CO₂ was always higher than the expected value, assuming equilibrium with atmospheric CO₂, indicating that they are supersaturated in relation to the overlying atmosphere. Table 2 shows the calculated CO₂ flux across the water/air interface from the other three sampled lakes (Tupé, Calado, Óleo).

As expected, the results show that CO₂ equilibrium is seldom attained, principally due to physical, biological and chemical factors that affect the concentration and exchange of CO₂ between the air and water phases.⁶ According to Cole *et al.*,² only 7% of a total of 1835 lakes investigated were within ±20% of equilibrium with the atmosphere, and 87% were supersaturated.

4. Conclusions

The proposed flow analysis system is characterized by a simple set-up, an inexpensive apparatus and ease of operation. It can be adapted to perform fieldwork and *in situ* measurements. The principal advantages of this system are the possibility to perform inorganic carbon speciation in natural waters without the need to know the sample pH and the relevant thermodynamic constants, and the fact that it uses only low-cost, stable reagents (deionized water and H₂SO₄).

It should also be mentioned that the possibility of measuring *in situ* both aqueous and gaseous CO₂ using the same system manifold is important in flux studies at the water/air interface of natural reservoirs.

All the lakes studied were far from thermodynamic equilibrium, either showing supersaturation or undersaturation. Furthermore, the undersaturation condition was obtained only for a hypereutrophic lake where positive (invasive) CO₂ fluxes were generated.

Acknowledgements

The authors thank Dr Ivo Raimundo Jr. for helpful comments on the manuscript.

References

- 1 J. J. Cole and N. F. Caraco, *Limnol. Oceanogr.*, 1998, **43**, 647.
- 2 J. J. Cole, N. F. Caraco, G. W. Kling and T. K. Kratz, *Science*, 1994, **265**, 1568.
- 3 T. Takahashi, *Oceanus*, 1989, **29**, 22.
- 4 E. C. V. Butler and D. J. Mackey, *Sci. Total Environ.*, 1992, **112**, 165.
- 5 A. Poisson, F. Culkin and P. Ridout, *Deep-Sea Res.*, 1990, **37**, 1647.
- 6 C. Goyet, D. R. Walt and P. G. Brewer, *Deep-Sea Res.*, 1992, **39**, 1015.
- 7 T. Takahashi and P. Kaiteris, *Earth Planet. Sci. Lett.*, 1976, **32**, 451.
- 8 R. M. Carlson, *Anal. Chem.*, 1978, **50**, 1528.
- 9 C. Pasquini and L. C. de Faria, *Anal. Chim. Acta*, 1987, **193**, 19.
- 10 W. F. Jardim, C. Pasquini, J. R. Guimarães and L. C. de Faria, *Water Res.*, 1990, **24**, 351.
- 11 T. Aoki, Y. Fujimaru, Y. Oka and K. Fujie, *Anal. Chim. Acta*, 1993, **284**, 167.
- 12 P. O. J. Hall and R. C. Aller, *Limnol. Oceanogr.*, 1992, **37**, 1113.
- 13 C. Pasquini and M. C. H. Silva, *J. Braz. Chem. Soc.*, 1999, **10**, 85.
- 14 J. T. Borges, MSc Thesis, Universidade Estadual de Campinas, Brazil, 1998.
- 15 F. V. Almeida, Master Thesis, University of Campinas, Brazil, 1998.
- 16 J. C. Miller and J. N. Miller, *Statistics for Analytical Chemistry*, Ellis Horwood Ltd., New York, 1984, p. 99.
- 17 W. Stumm and J. J. Morgan, *Aquatic Chemistry*, Wiley-Interscience Publication, New York, 3rd edn., 1996, p. 214.
- 18 R. Wanninkhof, J. R. Ledwell and J. Crucius, in *Air Water Gas Transfer*, ed. S. C. Wilhelms and J. S. Gulliver, American Society of Civil Engineers, New York, 1991, p. 441.
- 19 W. F. Jardim, J. R. Guimarães and H. E. Allen, *Ciênc. Cult.*, 1991, **43**, 454.
- 20 M. Frankignoulle, I. Bourge and R. Wollast, *Limnol. Oceanogr.*, 1996, **41**, 365.
- 21 A. A. Mozeto and A. L. S. Albuquerque, *Ciênc. Cult.*, 1997, **49**, 25.